

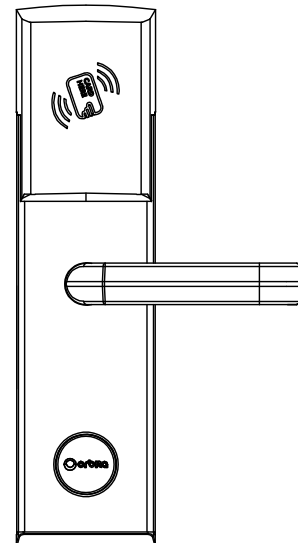

www.orbitausa.com



Orbita Hotel Lock
E3092A Installation and User Manual

CONTENTS

| | |
|------------------------------------|-----|
| 1: Introduction | P1 |
| 1-1: Product Dimensions | |
| 1-2: Technical Specifications | |
| 1-3: Packing Slip | |
| 1-4: Application | |
| 2: Installation | P5 |
| 3. Operation Guide | P8 |
| 4. Daily Maintenance and Care | P9 |
| 5. Troubleshooting | P9 |
| 6. After-sale Service and Warranty | P10 |

1: Introduction

Thank you for purchasing Orbita Hotel Door Lock E3092A. The product is made of grade 304 stainless steel with a PVC card reader cover, with strong resistance to impact, corrosion and abrasion. The door lock PCB is waterproof with stable and reliable quality.

E3092A Door Lock can support other types of hotel management software, Fidelio/Opera, and Orbita wireless portable programmer for door lock setting, data collection and download functions. Certified by European CE and U.S. FCC, our products adopt the American standard 5-point tongue lock body with an anti-shim plunger design and an abnormal latch bolt alert for double security, stability and reliability. Functions such as door left open warning, low battery voltage warning, channel function and all-in-one function are available.

1-1: Product Dimensions (unit: mm)

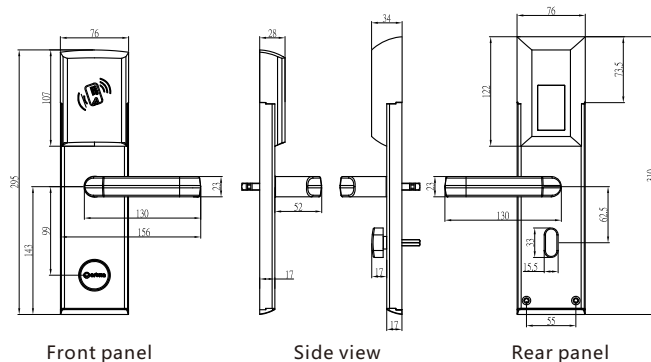

Standard Lock Body Dimensions (unit: mm)

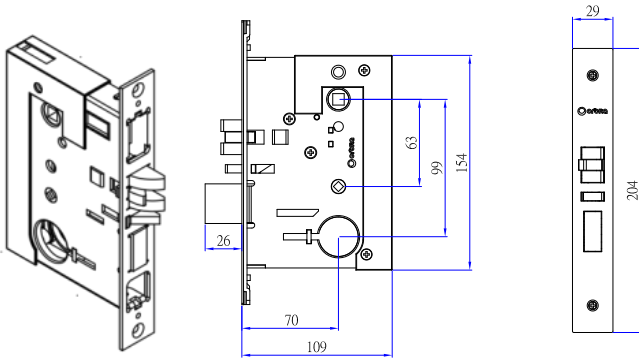

1-2: Technical Specifications

| | |
|---------------------|---|
| Panel dimensions | L295*W76*D26 mm |
| Material | Grade 304 stainless steel |
| Operating Voltage | DC 6V (4 AA dry batteries) |
| Operating Power | Quiescent current: < 30 μ A; dynamic current: < 200 mA |
| Battery Life | Provide up to 150,000 operations, and last over one year |
| Working Environment | Temperature: -20 $^{\circ}$ C – 60 $^{\circ}$ C; Relative Humidity: 20% – 90% |
| Card Type | Mifare 1 card |
| Low Voltage Warning | When the battery voltage is lower than 4.8V, a buzzer will beep. After that, the lock lasts about 100 operations |
| Activity Log | Stores up to 1,680 pieces of logs (depending on the configuration) |
| Mechanical Key | Unlock by mechanic keys |

1-3: Packing Slip

| | |
|--------------------|--|
| Front panel | *1 |
| Rear panel | *1 |
| Lock body | *1 |
| Cylinder | *1 |
| Keys | one key for multiple locks: 6% of the number of locks; one key for one lock: 2 keys for every lock |
| Cardboard cutout | one for the sample lock, and three to ten for every batch (subject to actual quantities) |
| Batteries | four batteries for every lock |
| Cylinder box | *1 |
| Screw package | *1 |
| Striking plate | *1 |
| Striking plate box | *1 |
| Side trim | *1 |

1-4: Application

E3092A Lock can be used in hotels, hospitals, schools and apartments, which comes with Orbita management system to save time and costs.

- Door thickness 32-70 mm
- Door types: Wooden, metal and composite doors

2: Installation

Please refer to the number below for the installation sequence

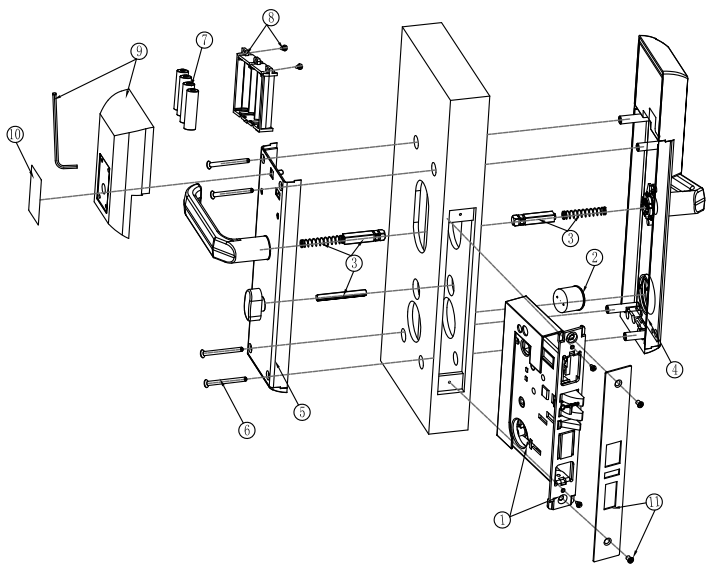

Door Lock Accessories

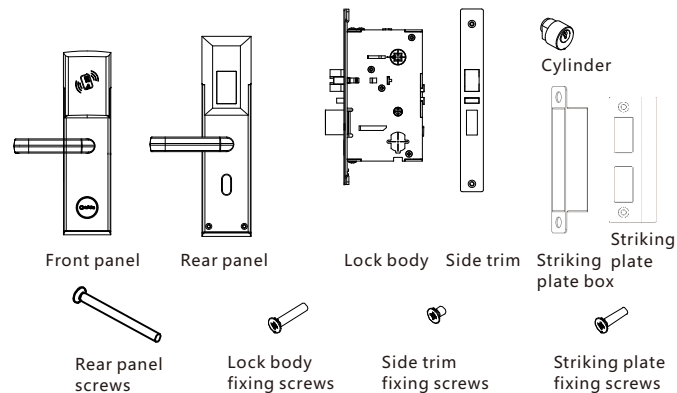

Installation Steps

1. Please choose the correct door lock in accordance with the door swing direction

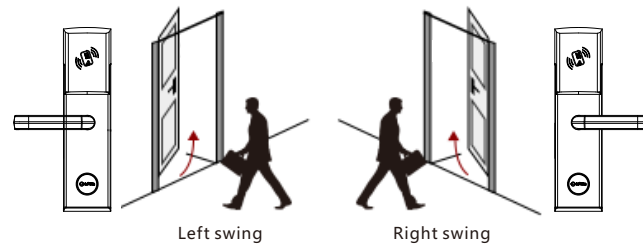

2. Drill holes using the cardboard cutout provided

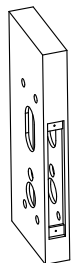

(Door plank)

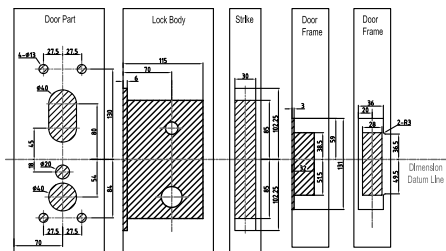

(Cardboard cutout)

3: Install the lock body and put the cylinder into it, and then fasten with screws

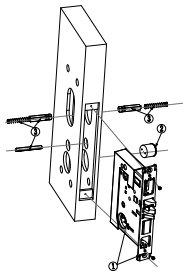

4: Fasten the front and rear panels with screws. Note that the holes in both panels should be aligned

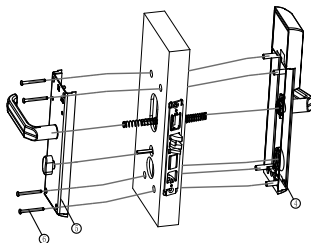

5: Install the battery box and install the battery box onto the rear panel

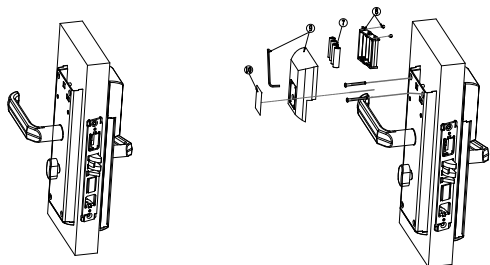

6: Install the side trim panel and lock it with screws

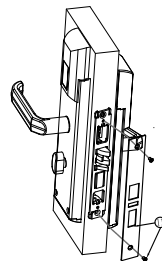

7: Install the strike plate and side plate

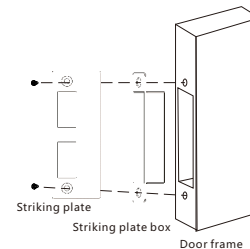

8: After the installation, open the key cover on the front panel. Use the key to unlock the door and check whether the handle and double-lock features work properly. If the door does not unlock or the handle or double-lock does not function well, check whether the cylinder, the square shafts of the handle and the deadbolt knob are installed correctly.

9: If no issue is found during the above steps, please use the cards already set up to swipe at the display area of the front panel and check whether the door unlocks.

3. Operation Guide

3-1: Unlock by card: Swipe the card and you will hear a beep with blue light lit up. Then press down the handle to unlock.

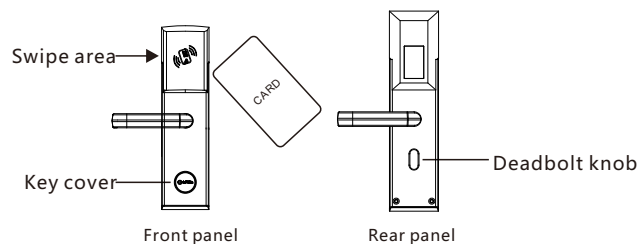

3-2: Lock from inside: Rotate the deadbolt knob on the rear panel for the double lock function (Note: The card needs to be encoded by the compatible management software and card encoder before use. Please refer to the "Orbita Hotel Lock System Management Software User Manual" for details.

4. Daily Maintenance and Care

- Avoid contact with corrosive liquids as this may damage the plating of the lock.
- Do not hang heavy objects on the handle to protect it from dislocation or abrasion.
- Please replace the batteries in time when the battery voltage is low, and pay attention to its polarities.
- Use water and dry towels for cleaning. Do not use other corrosive cleaning agents.
- Please contact customer service for help if the lock body does not rotate smoothly. And do not disassemble it on your own.
- Please keep the keys in a safe place in case of an emergency.
- It is recommended to check the door lock once every six months or once a year to avoid the loose screws and handles affecting regular functions.

5. Troubleshooting

Problem: Two red blinks and two beeps indicate that either it is the guest card for other rooms, or the maintenance card has exceeded its specified number of times for unlocking.

Solution: Open the door with the correct guest card or reset the maintenance card.

Problem: Three red blinks and three beeps indicate that the valid time period of the card does not match the lock.

Solution: The guest card has expired, please issue a new card or update the lock's time.

Problem: Four red blinks and four beeps indicate that the card has not been authorized.

Solution: Authorize the card with a setting card.

Problem: Five red blinks and five beeps indicate that the card has been suspended.

Solution: If the card has been suspended, it cannot be used. Please use a new card.

Problem: Six red blinks and six beeps indicate that the door has been double-locked.

Solution: A double-locked door can only be opened by the correct guest card and a master card.

Problem: Seven red blinks and seven beeps indicate that the lock has been restricted for opening by a restriction card.

Solution: The lock can only open with an additional reading of a master card or a restriction card.

Problem: Eight red blinks and eight beeps indicate that the lock has been authorized by a setting card from other systems.

Solution: If the password is unknown, the only solution is to perform compulsory authorization for the lock.

6. After-sale Service and Warranty

If the product does not match the real door lock, the real one should prevail!

If you have any questions during the installation and use of the door lock, please call our service hot-line, and we are always at your service!