

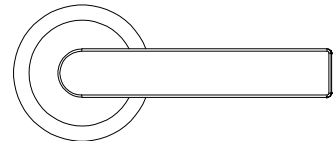

[www.orbitausa.com](http://www.orbitausa.com)

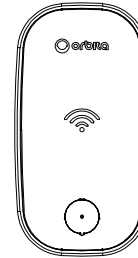

## **Orbita Hotel Lock**

S3078 Installation and User Manual

1: Introduction	P1
1-1: Product Dimensions	
1-2: Technical Specifications	
1-3: Packing Slip	
1-4: Application	
2: Installation	P4
3: Operation Guide	P8
4. Daily Maintenance and Care	P8
5. Trouble shooting	P9

Thank you for purchasing Orbita Hotel Door Lock S3078. The product is made of grade 304 stainless steel with a PVC card reader cover, with strong resistance to impact, corrosion and abrasion.

S3078 Door Lock can support other types of hotel management software, Fidelio/Opera, and Orbita wireless portable programmer for door lock setting, data collection and download functions. Certified by European CE and U.S. FCC, our products adopt the American standard 5-point tongue lock body with an anti-shim plunger design and an abnormal latch bolt alert for double security, stability and reliability. Functions such as door left open warning, low battery voltage warning, channel function and all-in-one function are available.

## 1-1: Product Dimensions (unit: mm)

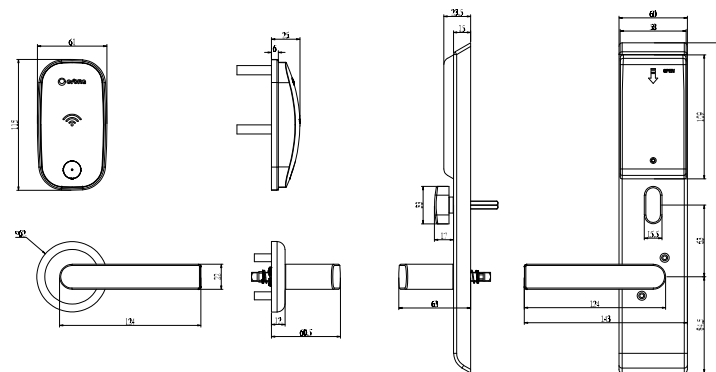

## Standard Lock Body Dimensions (unit: mm)

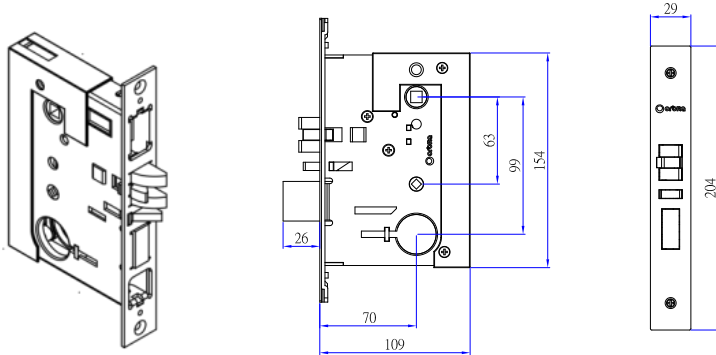

## 1-2: Technical Specifications

Panel dimensions	L125*W61*D22 mm
Material	Grade 304 stainless steel
Operating Voltage	DC 6V (4 AA dry batteries)
Operating Power	Quiescent current: < 30 $\mu$ A; dynamic current: < 200 mA
Battery Life	Provide up to 15,000 operations, and last over one year
Working Environment	Temperature: -20 °C – 60 °C; Relative Humidity: 20% – 90%
Card Type	Mifare 1 card
Low Voltage Warning	When the battery voltage is lower than 4.8V, a buzzer will beep. After that, the lock lasts about 100 operations
Activity Log	Stores up to 3,360 pieces of logs (depending on the configuration)
Mechanical Key	Unlock by mechanic keys

## 1-3: Packing Slip

Front panel	*1
Rear panel	*1
Lock body	*1
Cylinder	*1
Keys	one key for multiple locks: 6% of the number of locks; one key for one lock: 2 keys for every lock
Cardboard cutout	one for the sample lock, and three to ten for every batch (subject to actual quantities)
Batteries	four batteries for every lock
Cylinder box	*1
Screw package	*1
Striking plate	*1
Striking plate box	*1
Side trim	*1

## 1-4: Application

S3078 Lock can be used in hotels, hospitals, schools and apartments, which comes with Orbita management system to save time and costs.

- Door thickness 35-70 mm
- Door types: Wooden, metal and composite doors

## 2: Installation

Please refer to the number below for the installation sequence

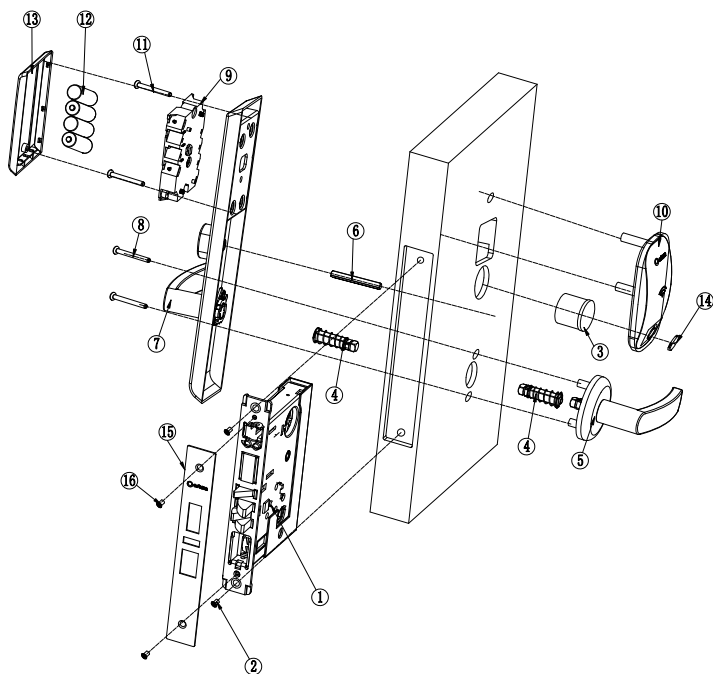

### Door Lock Accessories

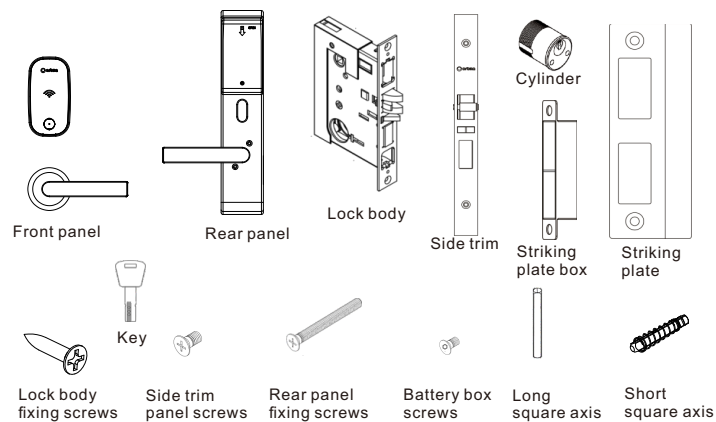

### Installation Steps

1. Please choose the correct door lock in accordance with the door swing direction

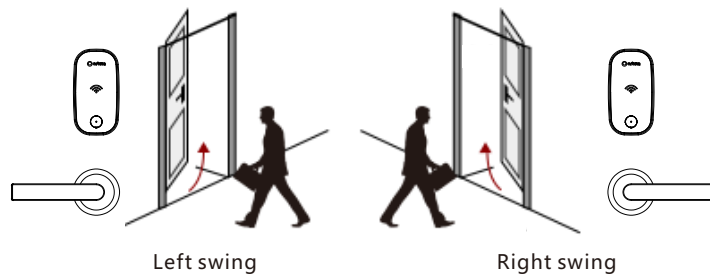

2. Drill holes using the cardboard cutout provided

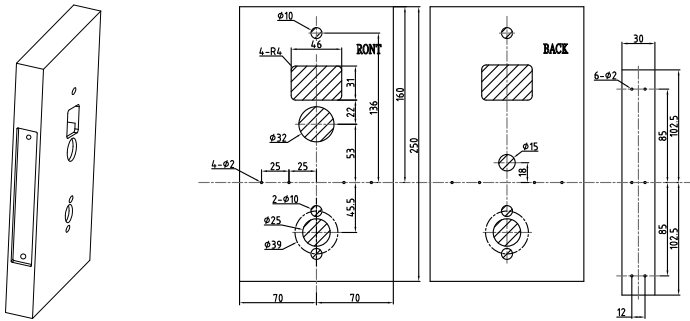

3: Install the lock body and put the cylinder into it, and then fasten with screws, Insert the short square shafts of the front and rear panels

4: Fasten the front and rear panels with screws. Note that the holes in both panels should be aligned

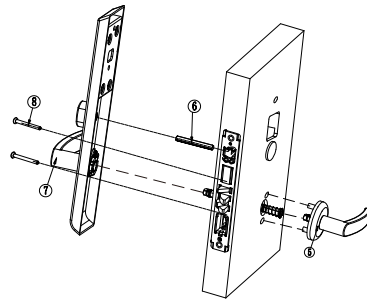
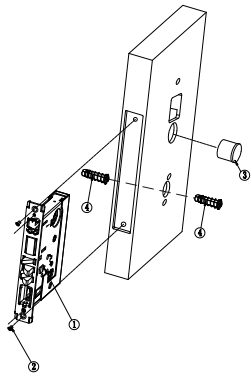

6: Align the hole position on the door panel and install the front sensing mask, insert the battery box on the rear panel and lock it with a long rod screw, install the battery, buckle the rear cover and lock it with a screw.

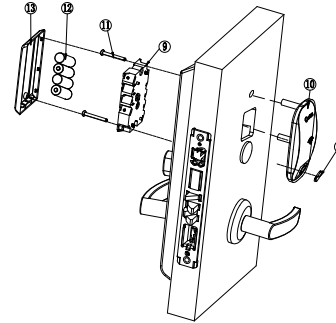

7: Install the strike plate and side plate

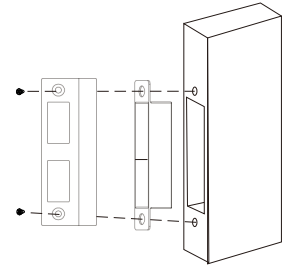

8: After the installation, open the key cover on the front panel. Use the key to unlock the door and check whether the handle and double-lock features work properly. If the door does not unlock or the handle or double-lock does not function well, check whether the cylinder, the square shafts of the handle and the deadbolt knob are installed correctly.

9: If no issue is found during the above steps, please use the cards already set up to swipe at the display area of the front panel and check whether the door unlocks.

## 3. Operation Guide

3-1: Unlock by card: Swipe the card and you will hear a beep with blue light lit up. Then press down the handle to unlock.

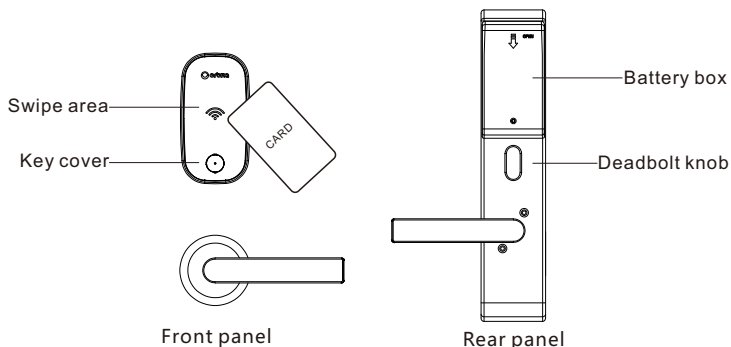

3-2: Lock from inside: Rotate the deadbolt knob on the rear panel for the double lock function (Note: The card needs to be encoded by the compatible management software and card encoder before use.

Please refer to the "Orbita Hotel Lock System Management Software User Manual" for details.

## 4. Daily Maintenance and Care

- Avoid contact with corrosive liquids as this may damage the plating of the lock.
- Do not hang heavy objects on the handle to protect it from dislocation or abrasion.
- Please replace the batteries in time when the battery voltage is low, and pay attention to its polarities.
- Use water and dry towels for cleaning. Do not use other corrosive cleaning agents.
- Please contact customer service for help if the lock body does not rotate smoothly. And do not disassemble it on your own.
- Please keep the keys in a safe place in case of an emergency.
- It is recommended to check the door lock once every six months or once a year to avoid the loose screws and handles affecting regular functions.

## 5. Troubleshooting

Problem: Two red blinks and two beeps indicate that either it is the guest card for other rooms, or the maintenance card has exceeded its specified number of times for unlocking.

Solution: Open the door with the correct guest card or reset the maintenance card.

Problem: Three red blinks and three beeps indicate that the valid time period of the card does not match the lock.

Solution: The guest card has expired, please issue a new card or update the lock's time.

Problem: Four red blinks and four beeps indicate that the card has not been authorized.

Solution: Authorize the card with a setting card.

Problem: Five red blinks and five beeps indicate that the card has been suspended.

Solution: If the card has been suspended, it cannot be used. Please use a new card.

Problem: Six red blinks and six beeps indicate that the door has been double-locked.

Solution: A double-locked door can only be opened by the correct guest card and a master card.

Problem: Seven red blinks and seven beeps indicate that the lock has been restricted for opening by a restriction card.

Solution: The lock can only open with an additional reading of a master card or a restriction card.

Problem: Eight red blinks and eight beeps indicate that the lock has been authorized by a setting card from other systems.

Solution: If the password is unknown, the only solution is to perform compulsory authorization for the lock.

If you have any questions during the installation and use of the door lock, please call our service hot-line, and we are always at your service!